



Fabric Roll-Up Doors Model A-2-B

SPECIFICATIONS:

- Note:** The dimensions shown on the drawing on the reverse side are component dimensions and they do not include operating clearances. They are to be used only as a guide for initial planning. Detailed drawings will be furnished for your particular application and final approval.
- Please note the alternate dimensions if the optional inside door seals are used.
- Based upon the inside jambs being flush with the inside of the header, you will need a mounting plate, for our J-Section (for holding the curtain on the header) built out 1 15/16" completely across the header and up a minimum of 12" from the bottom of the header for securing our J-Section, which must be mounted **LEVEL**. Our J-Section is 3" high and comes in 10' lengths with 13/32" diameter mounting holes on 12" centers.
- You will need a smooth surface at the inside of each jamb, 12" wide, floor to bottom of J-Section built out 1 1/4". If the optional inside door seals are used, a 3" spacer (or filler) will need to be mounted to the inside of the jambs. Please note the corners of the jamb have a 3/4" radius.
- You will need a minimum of 28" clear headroom space above the header at the drive end to accommodate our drive unit and to give you a clear door opening. The drive unit may be mounted at either end of the tube with the left hand end as standard. This location is determined from inside the room, looking out.
- The tubing will be 10" diameter weighing 19.68 lbs. per foot and will be shipped in 20' random lengths with beveled ends ready for field welding. Freight on tubing will be f.o.b. St. Louis, MO or the nearest warehouse. The door and its components will weigh 1500 lbs. and will be shipped f.o.b. Fostoria, OH. If the optional inside door seals are used, add 1000lbs.
- It will be your responsibility (or others) to supply the necessary guide rails as indicated on the drawing.
- It will be your responsibility (or others) to supply the necessary stud, loads, and power activated tools for fastening our rubber sill material to the floor.
- Your building should have the following:
 - A **LEVEL** concrete floor.
 - Guide rails in place and **PLUMB**.
 - Jamb and header details worked up in advance per specifications.
 - Proper electrical power supplied to a junction box where the controls are to be mounted.
 - No obstructions in the way of the door opening.We would estimate 80 man hours needed for the installation of this door. If the optional inside door seals are used, add 24 man hours.
- Our standard doors are guaranteed for 75 MPH protection when locked down. 100 MPH protection is available as an option. Doors are fully operable in winds up to 35 MPH.

Lintel loading figures, both horizontal and vertical, will be supplied once the height of the door opening is determined.

Welding equipment, service wiring to a junction box at the door jamb, scaffolding, welding of the tube and all other standard installation tools are to be supplied by others.

OPTIONAL FEATURES:

INSIDE DOOR SEALS:

Inside door seals are used on tall doors, heated buildings and in cold climates. If in doubt, leave room at the inside jambs and they can be added later. The seals come complete with limit switches so that door cannot operate unless inside door seals are locked back and out of the way.

100 MPH WIND PROTECTION:

Some areas and codes require a wind service factor of 100 MPH-38# per square foot loading. For this, one additional portable hold down is required, plus additional clips in the J-Section on certain installations.

DEBRIS APRON:

Used on applications with dust, paint, etc. The apron unfolds over the tube as door is lowered and it rolls up on the tube when raised.

PORTABLE OUTSIDE BUMP ROLLS:

On applications of two or more doors in a building at opposite ends or 90° to each other and without a divider between, it is necessary to incorporate our portable bump rolls.

They protect the door, when it is down, against a wind tunnel (or suction load).

EXPLOSION-PROOF MOTORS AND CONTROLS:

Applications for paint room doors and dusty areas may require explosion-proof motors and/or controls. Consult the factory for prices and delivery.

SUBSTITUTE VOLTAGES:

On applications requiring voltages other than 230/460V 3 phase 60 cycles, consult the factory. Delivery and prices may be affected.

DRIVE UNIT MOUNTING:

The drive unit may be mounted at either end of the tube. Left hand is standard with the location determined from inside the room looking out.

SUPERVISION:

Optional factory supervision is available for installation or field inspection, if desired.

A-2-B

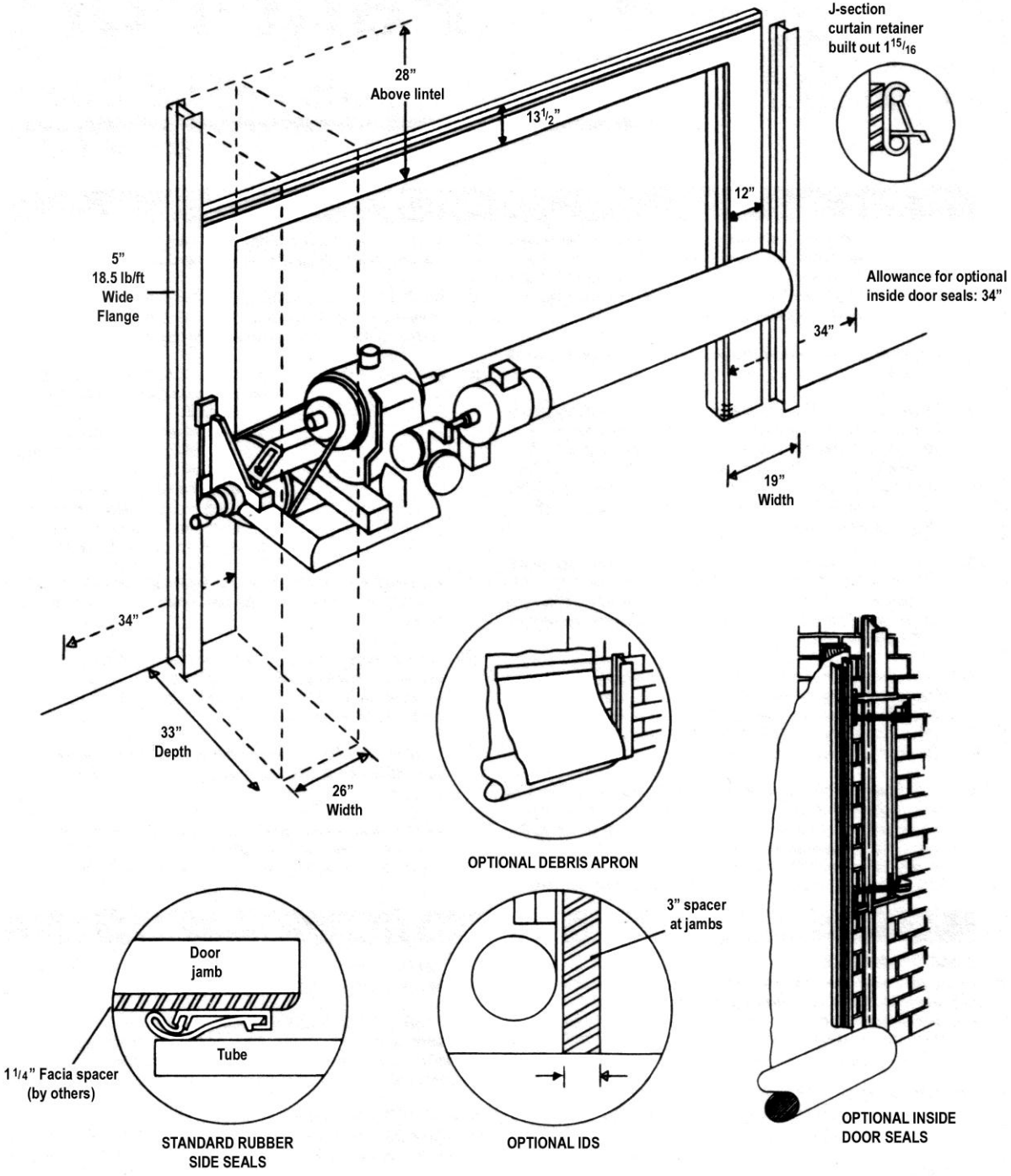

(Safety Guards not shown)